

cleanLED™

LED LIGHTING FIXTURES FOR CONTROLLED ENVIRONMENTS





cleanLED™ sets new standards for controlled environment lighting systems

- Edge-lit LED optics eliminates glare and minimizes shadows
- Innovative housing design maximizes LED performance/longevity and minimizes contamination
- Fully listed and certified for surgical suite sanitation, leakage, RFI and hazardous location requirements
- Optional 405nm LED disinfecting technology kills bacteria – see inside back cover

Edge-Lit LED Optics

cleanLED's edge-lit optical system eliminates direct glare and minimizes shadows. The illustration demonstrates that the LEDs (1) are not visible from normal viewing angles eliminating direct glare and minimizes shadows. The light guide plate (2) channels the light through the plate that is etched with a pattern that captures and directs the light through a diffuser (3) into wide uniform controlled distributions of light.

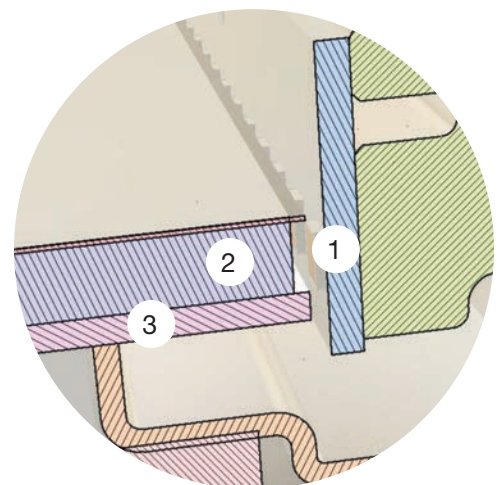

Low-Profile Housing

The low-profile cleanLED housing (<2.0”) is designed to maximize thermal conductivity of heat away from the junction points of the LEDs. Three factors impact the effectiveness of the thermal conductivity – material, mass and surface area. The choice of aluminum over CRS increases thermal conductivity at least 300%. In order to maximize mass the housing is extruded with thicknesses >.20” compared to .048” thickness of 18-gauge CRS. Adding fins to the extrusion profile increases the surface area by 70% over 18-gauge CRS.

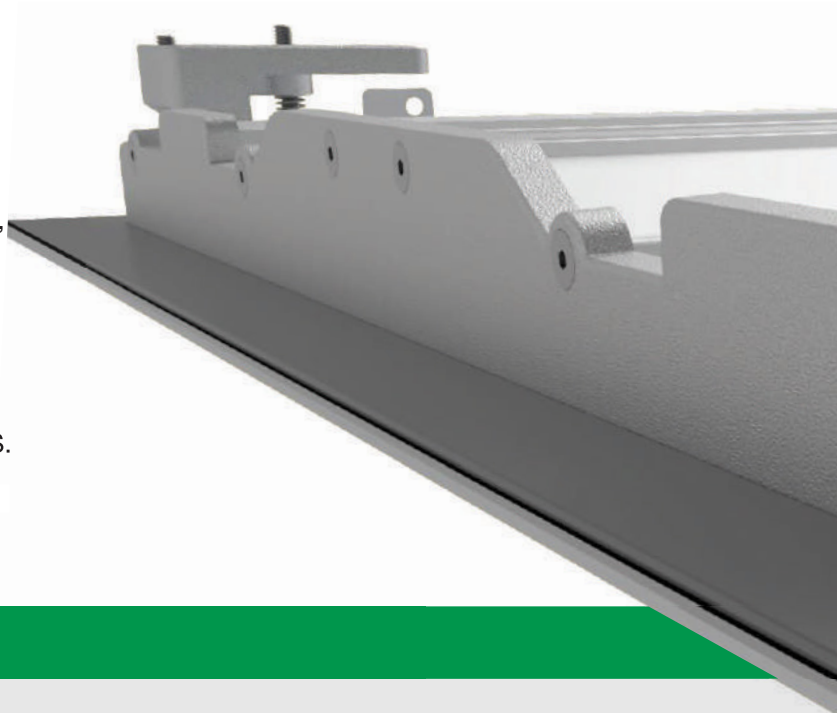

Environmental Challenges of Controlled Environment Lighting

In addition to meeting all of the lighting and mechanical challenges of controlled environment lighting, cleanLED is listed and certified to meet all environmental challenges – leakage, contamination, corrosion, toxicity, cleanability, electromagnetic interference and energy efficiency.



cleanLED is IP66 rated to assure that pathogens and particulates will not enter or pass through the lighting fixture. IP66 is the highest level of dust and moisture protection without entering the categories for submersible lighting fixtures.



NSF/ANSI 2 Splash Zone is a listing that addresses materials, design and construction as it relates to ease of cleanability, corrosion resistance and toxicity. cleanLED is constructed from stainless steel and aluminum and is impervious to corrosion. The enclosure has been designed to produce a progressive surface with the ceiling structure to promote ease of cleanability. The construction of the enclosure is robust and will withstand the most aggressive cleaning protocols.



Electronic equipment in controlled environments must be protected from radiated and conducted emissions that might compromise the patient, surgical procedures and imaging operations. “Military Standard 461F-Air Force/Navy Fixed” testing procedures provide tangible proof that cleanLED will operate within ranges (RE and CE) that are safe for controlled environments.



cleanLED 2x4 luminaires are Design Lights Consortium Qualified - DLC qualified. DLC qualified is a prerequisite for most utility rebate programs. According to DLC, “When you purchase a product with DLC certification you can rest assured that you’ve chosen a highly scrutinized product that has been produced to some of the highest industry standards for quality and efficiency.”

cleanLED™, the first LED controlled environment lighting series designed from the ground up to maximize the benefits of LED technology, interfaces with new contemporary ceiling systems and meets all the listing and certification requirements related to contamination (leakage, cleanability, corrosion, toxicity, electromagnetic interference and hazardous locations).

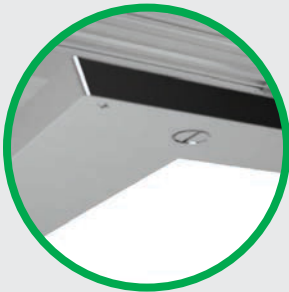
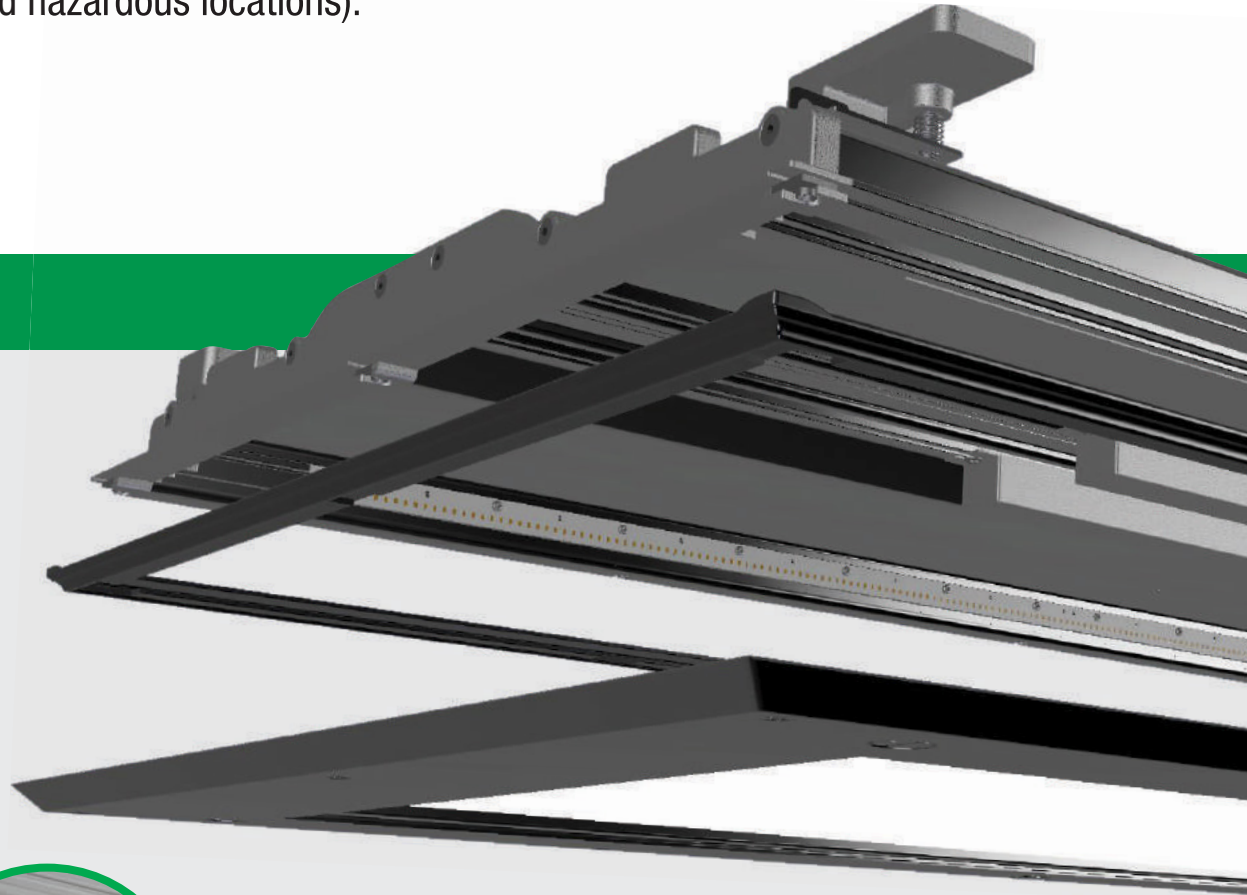

LENS FRAME

The stainless steel lens frame corners are die-formed and trimmed rather than notched and seam welded. Eliminating welded corners avoids destroying the chromium content and compromising the corrosion resistance of the stainless steel. Additionally, the lens frames fasteners close proximity to the lens frame perimeter avoids cantilevering and promotes ceiling contact.

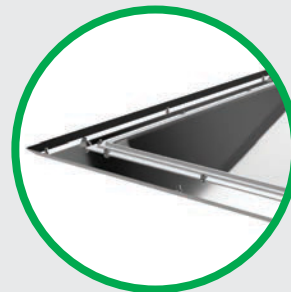

IMPACT RESISTANT LENS

The clear impact-resistant lens is silicone sealed and securely held in place with continuous lens retention brackets with mitered corners.

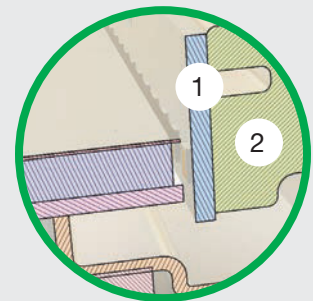
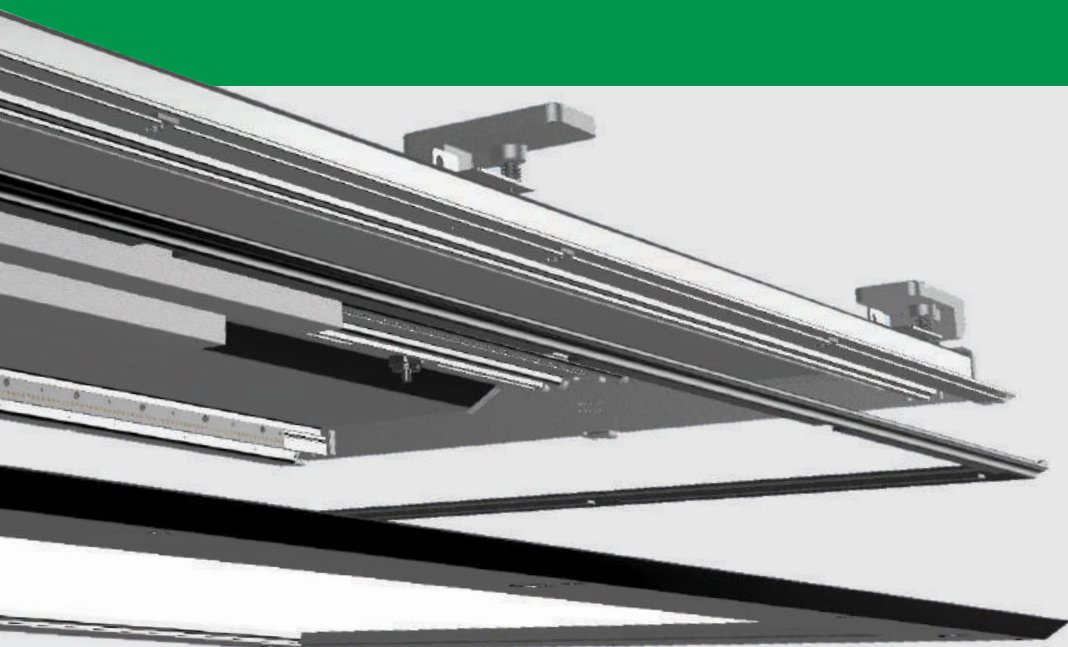

LED MODULES

The LED modules (1) are secured to a heavy gauge extruded aluminum heat sink housing (2). The thermal benefits of the aluminum heat sink housing promote LED efficiency and longevity.

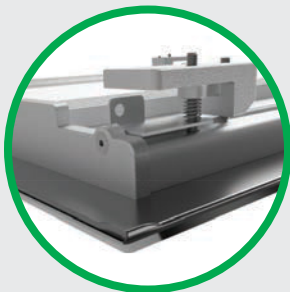

LOW-PROFILE HOUSING

The low-profile housing (<2.0") with patented swing-out arm installation mechanism allows universal installation in traditional gypsum, 2.0" walkable ceiling panels and 2.0" T-bar grid ceiling systems without opening the fixture – dramatically reducing installation costs.

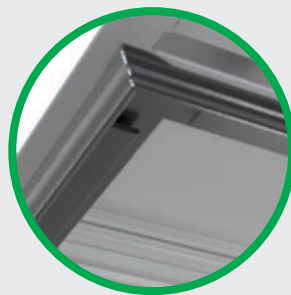

GASKET

The patented one-piece injection molded closed cell silicone gasket provides a consistent custom fit between the ceiling/housing flange/lens frame, eliminates potential failure of vulcanized corners, and produces maximum seal with minimum compression.

DIMENSIONAL DATA

Housing requires a ceiling cutout of 9.75" x 45.75"

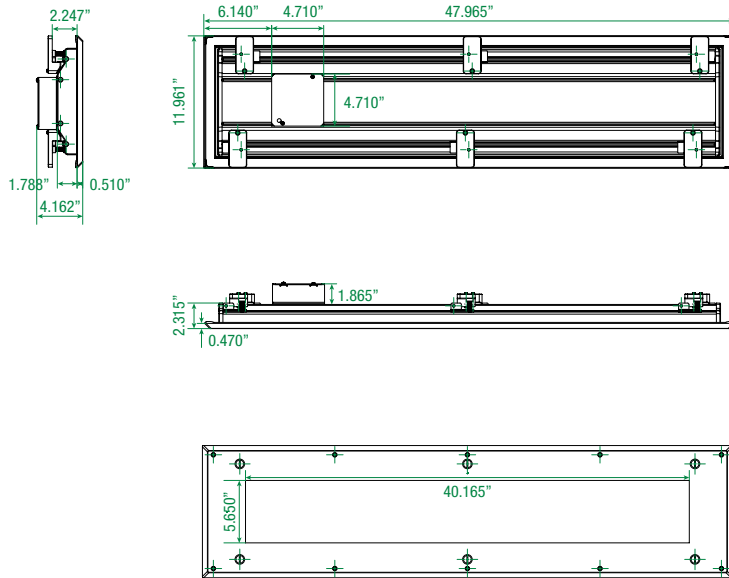

POLAR PLOTS

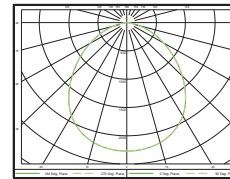

CLF14-S1-C-UV / Lumens: 5559

Zone	Lumens	% of Luminaire
0-40	2857	51.4%
0-60	4716	84.8%
0-90	5559	100.0%
90-180	0	0%

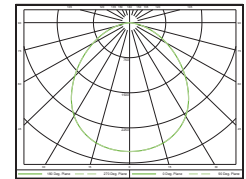

CLF14-M1-C-UV / Lumens: 6746

Zone	Lumens	% of Luminaire
0-40	3468	51.4%
0-60	5724	84.9%
0-90	6746	100.0%
90-180	0	0%

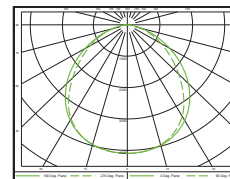

CLF14-H1-C-UV / Lumens: 10030

Zone	Lumens	% of Luminaire
0-40	5159	51.4%
0-60	8514	84.9%
0-90	10030	100.0%
90-180	0	0%

SPECIFICATIONS

Housing: Low-profile (2.0") extruded aluminum housing with die-cast aluminum end caps. Extrusion profile produces internal heat sink and external heat fins to conduct/dissipate heat away from LED junction point to the housing exterior. Housing will support 1,000 pounds for walkable ceiling applications.

Lens Frame: One-piece, deep-draw fabricated Type 304 or Type 316 stainless steel lens frame free of surface welding. 60 degree beveled edge produces a progressive surface with the ceiling.

Optics: Edge lit LED optics. Light guide panel provides even facial illuminates and eliminates glare. 3000-6000K CCT and a variety of filtering options available.

Electrical: 100-277 VAC integral high efficiency driver and power supply (>0.90 power factor). Dimmable (0-10V). Optional 1100 Lumens 90-minute battery back-up (regular and Class I, Division 2/ Class II, Division 2).

Installation: Integral junction box or whip option. Designed for universal installation - 2.0 T-Bar grid, modular ceiling panel (2" -3") and stick-built gypsum ceilings. Wiring and installation does not require removal of lens frame.

Listings, Ratings, Certifications and Protocols: IP66 (ISO60598); Hazardous Locations - Class I, Division 2; Class II, Division 2; NSF/ANSI 2 (Splash Zone); LM79; LM80; DLC Qualified. ETL Listed. Optional MIL STD 461F.

ORDERING INFORMATION

SERIES	LIGHT ENGINE	COLOR TEMP.	VOLTAGE	HOUSING	LENS FRAME	LENS	BACKUP	CERTS
CLF14			UV	HAL				
CLF14= cleanLED recessed flange or 2.0" T-bar grid 1x4	S1*= 60 W/ 5,600 lm M1*= 80 W/ 6,800 lm H1= 130 W/ 10,000 lm	W= 3,500K N= 4,000K C= 5,000K A= Amber UV Filtering Y= Yellow 101	UV= Universal Voltage (100-277 VAC)	HAL= Extruded aluminum with die-cast end caps	LFSS304= 18-gauge Type 304 Stainless Steel LFSS316= 18-gauge Type 316 Stainless Steel	CTG= .125" Clear Tempered Glass CIA= .125" Clear Impact Acrylic	NB= No Backup IBB= Integral Battery Back-up HBB= Class I, Div 2 Battery Backup	MS= MIL STD 461F C1D2= Class I, Div 2 C2D2= Class II, Div 2

All lumens at steady state room temp
*Battery backup available

PROJECT INFORMATION

Project Name/Location _____

Fixture Type _____

Fixture Quantity _____

Catalog Number _____

DIMENSIONAL DATA

Housing requires a ceiling cutout of 21.75" x 21.75"

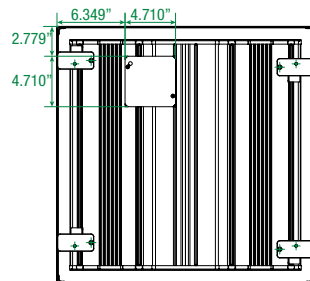
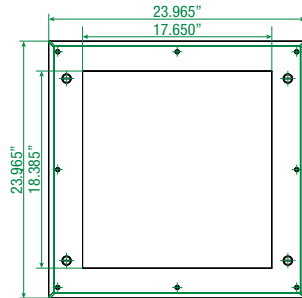
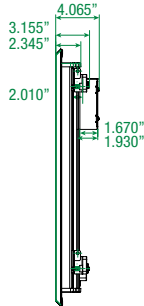

POLAR PLOTS

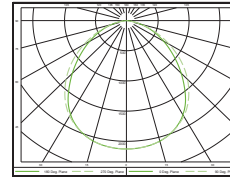

CLF22-S1-C-UV / Lumens: 5382

Zone	Lumens	% of Luminaire
0-40	2713	50.4%
0-60	4530	84.2%
0-90	5382	100.0%
90-180	0	0%

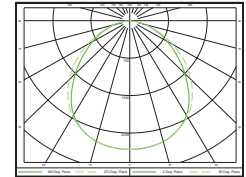

CLF22-M1-C-UV / Lumens: 6527

Zone	Lumens	% of Luminaire
0-40	3289	50.4%
0-60	5491	84.1%
0-90	6527	100.0%
90-180	0	0%

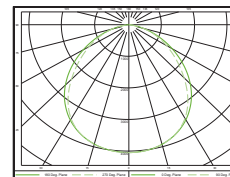

CLF22-H1-C-UV / Lumens: 10270

Zone	Lumens	% of Luminaire
0-40	5149	50.1%
0-60	8638	84.1%
0-90	10275	100.0%
90-180	0	0%

SPECIFICATIONS

Housing: Low-profile (2.0") extruded aluminum housing with die-cast aluminum end caps. Extrusion profile produces internal heat sink and external heat fins to conduct/dissipate heat away from LED junction point to the housing exterior. Housing will support 1,000 pounds for walkable ceiling applications.

Lens Frame: One-piece, deep-draw fabricated Type 304 or Type 316 stainless steel lens frame free of surface welding. 60 degree beveled edge produces a progressive surface with the ceiling.

Optics: Edge lit LED optics. Light guide panel provides even facial illuminates and eliminates glare. 3000-6000K CCT and a variety of filtering options available.

Electrical: 100-277 VAC integral high efficiency driver and power supply (>0.90 power factor). Dimmable (0-10V). Optional 1100 Lumens 90-minute battery back-up (regular and Class I, Division 2/ Class II, Division 2).

Installation: Integral junction box or whip option. Designed for universal installation - 2.0 T-Bar grid, modular ceiling panel (2"-3") and stick-built gypsum ceilings. Wiring and installation does not require removal of lens frame.

Listings, Ratings, Certifications and Protocols: IP66 (ISO60598); Hazardous Locations - Class I, Division 2; Class II, Division 2; NSF/ANSI 2 (Splash Zone); LM79; LM80; DLC Qualified. ETL Listed. Optional MIL STD 461F.

ORDERING INFORMATION

SERIES	LIGHT ENGINE	COLOR TEMP.	VOLTAGE	HOUSING	LENS FRAME	LENS	BACKUP	CERTS
CLF22	<input type="checkbox"/>	<input type="checkbox"/>	UV	HAL	<input type="checkbox"/>	<input type="checkbox"/>	<input type="checkbox"/>	<input type="checkbox"/>
CLF22= cleanLED	S1*= 60 W/ 5,800 lm M1*= 80 W/ 6,800 lm H1= 130 W/ 10,300 lm	W= 3,500K N= 4,000K C= 5,000K A= Amber UV Filtering Y= Yellow 101	UV= Universal Voltage (100-277 VAC)	HAL= Extruded aluminum with die-cast end caps	LFSS304= 18-gauge Type 304 Stainless Steel LFSS316= 18-gauge Type 316 Stainless Steel	CTG= .125" Clear Tempered Glass CIA= .125" Clear Impact Acrylic	NB= No Backup IBB= Integral Battery Back-up HBB= Class I, Div 2 Battery Backup	MS= MIL STD 461F C1D2= Class I, Div 2 C2D2= Class II, Div 2

All lumens at steady state room temp
*Battery backup available

PROJECT INFORMATION

Project Name/Location _____

Fixture Type _____

Fixture Quantity _____

Catalog Number _____

DIMENSIONAL DATA

Housing requires a ceiling cutout of 21.75" x 45.75"

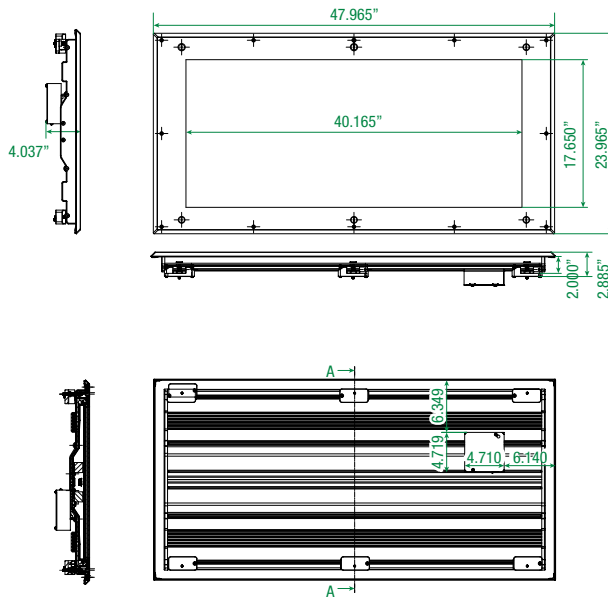

POLAR PLOTS

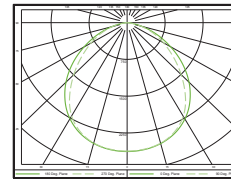

CLF24-S1-C-UV / Lumens: 6618

Zone	Lumens	% of Luminaire
0-40	5392	50.5%
0-60	8992	84.2%
0-90	10678	100.0%
90-180	0	0%

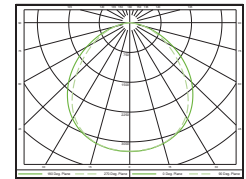

CLF24-M1-C-UV / Lumens: 8165

Zone	Lumens	% of Luminaire
0-40	4122	50.5%
0-60	6873	84.2%
0-90	8165	100.0%
90-180	0	0%

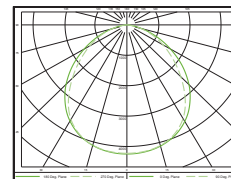

CLF24-H1-C-UV / Lumens: 10680

Zone	Lumens	% of Luminaire
0-40	5159	51.4%
0-60	8514	84.9%
0-90	10030	100.0%
90-180	0	0%

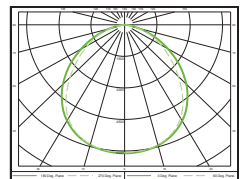

CLF24-VH1-C-UV / Lumens: 15370

Zone	Lumens	% of Luminaire
0-40	7754	50.4%
0-60	12933	84.1%
0-90	15363	100.0%
90-180	0	0%

SPECIFICATIONS

Housing: Low-profile (2.0") extruded aluminum housing with die-cast aluminum end caps. Extrusion profile produces internal heat sink and external heat fins to conduct/dissipate heat away from LED junction point to the housing exterior. Housing will support 1,000 pounds for walkable ceiling applications.

Lens Frame: One-piece, deep-draw fabricated Type 304 or Type 316 stainless steel lens frame free of surface welding. 60 degree beveled edge produces a progressive surface with the ceiling.

Optics: Edge lit LED optics. Light guide panel provides even facial illuminates and eliminates glare. 3000-6000K CCT and a variety of filtering options available.

Electrical: 100-277 VAC integral high efficiency driver and power supply (>0.90 power factor). Dimmable (0-10V). Optional 1100 Lumens 90-minute battery back-up (regular and Class I, Division 2/ Class II, Division 2).

Installation: Integral junction box or whip option. Designed for universal installation - 2.0 T-Bar grid, modular ceiling panel (2" -3") and stick-built gypsum ceilings. Wiring and installation does not require removal of lens frame.

Listings, Ratings, Certifications and Protocols: IP66 (ISO60598); Hazardous Locations - Class I, Division 2; Class II, Division 2; NSF/ANSI 2 (Splash Zone); LM79; LM80; DLC Qualified. ETL Listed. Optional MIL STD 461F.

ORDERING INFORMATION

SERIES	LIGHT ENGINE	COLOR TEMP.	VOLTAGE	HOUSING	LENS FRAME	LENS	BACKUP	CERTS
CLF24			UV	HAL				
CLF24= cleanLED	S1*= 60 W/ 6,600 lm M1*= 76 W/ 8,200 lm H1= 100 W/ 10,700 lm VH1= 160 W/ 15,400 lm	W= 3,500K N= 4,000K C= 5,000K A= Amber UV Filtering Y= Yellow 101	UV= Universal Voltage (100-277 VAC)	HAL= Extruded aluminum with die-cast end caps	LFSS304= 18-gauge Type 304 Stainless Steel LFSS316= 18-gauge Type 316 Stainless Steel	CTG= .125" Clear Tempered Glass CIA= .125" Clear Impact Acrylic	NB= No Backup IBB= Integral Battery Back-up HBB= Class I, Div 2 Battery Backup	MS= MIL STD 461F C1D2= Class I, Div 2 C2D2= Class II, Div 2

All lumens at steady state room temp
*Battery backup available

PROJECT INFORMATION

Project Name/Location _____

Fixture Type _____

Fixture Quantity _____

Catalog Number _____

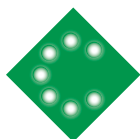

clear-vu
lighting

1150 Motor Parkway | Central Islip, NY 11722 | 516.941.3737 | lighting@clear-vu.com
www.clearvulighting.com